



THE NATIONAL SMALL INDUSTRIES CORPORATION LIMITED

(A Govt. of India Enterprise)

EXHIBITION-CUM MARKETING DEVELOPMENT BUSINESS PARK

KUSHAIGUDA, ECIL P.O., HYDERABAD 500062

Ph: 040-27125802,27121422, 27126646, Tel fax 27130204, Fax- 27122303

Email: emdbphvd@nsic.co.in

Website: www.nsic.co.in

Ref No.: NSIC/EMDBP(HYD)/Admin.off/11

Date: 02-04-2012

To,

Sub: Supply and installation of tables and chares at NSIC-EMDBP, Hyderabad-reg.

Dear Sir,

You are requested to submit your quote for undertaking the subject work as per details given below on the terms-conditions as mentioned in the **Annexure-A**.

S.No	Description	Unit	Qty.	Rate (Rs)	Amount (Rs)
1	D G M Main Table ; Table provided with mobile three drawer unit, drawer bottoms made in 9 mm thick pre laminated particle board. Size:1800 x 900 x 750mm Ht. Side Table : Side Table provided with a drawer, one PLB Keyboard and a PLB CPU trolley.	Set.	1		
2	Manager Main Table : Table provided with a storage unit of one drawer, one shutter, drawer bottoms made in 9mm thick pre laminated particle board. Size : 1500 x 600 x 750mm Ht. Side Table : Side Table provided with a drawer, one PLB Keyboard and a PLB CPU trolley.	Sets.	4		
3	Staff & Reception Tables : Table provided with a storage unit of one drawer, one shutter and a PLB keyboard, drawer bottoms made in 9mm thick pre laminated particle board. Size: 1200 x 600 x 750mm Ht.	No	3		
4a	DGM's Chair : Chair made with moulded plywood backing for seat & backrest, moulded polyurethane foam for seat & back revolving and synchro mechanism, PU arm rests, gas lift, 5 prong steel base, nylon twin castor wheel upholstered with a desired color of fabric.	No	1		
4 b	Manager's Chair : A low back chair of metal framed seat & back structure with revolving and tilting facility, gas lift height adjustment, pre moulded PU	No	4		

	foam cushioned, fabric covered, helical springs, self skinned PU arm rest and 5 prong PP base with nylon twin castor wheels.				
4 c	Staff Chair: Chair made with moulded plywood for seat, ABS cover for backrest, moulded polyurethane foam for seat and backrest, revolving and push back system, gas lift, PU arm rests, 5 prong PP base, nylon twin castor wheels, upholstered with desired colour of fabric.	No	2		
4 d	Receptionist Chair: Chair made with 25mm dia, 14 SWG (Standard wire gauge) MS (Mild steel) tubular framework duly powder coated to 50 microns with moulded plywood for seat and backrest, polyurethane (PU) foam for seat and backrest, PU armrests upholstered with desired colour of fabric.	No	1		
5	DGM Visitor Chairs: Chair is made with 25mm dia x 14G MS pipe for the main frame and the inner frames made from 19mm dia MS pipe duly powder coated, moulded polyurethane foam for seat and backrest, PU arm rests, upholstered with desired colour of fabric.	No	2		
6	Sofa - 3 Seater: Made with 50mm dia x 16G round tube for Legs and supports, 0.8mm thick perforated sheet of 18G for seat and back cushion covered with desired colour fabric, 20 x 40 x 59mm dia oval tubes for arm rests with 50 microns powder coated, Set comprises of three chairs fixed together.	No	1		
7	Sofa 2 Seater: Made with 50 x 50 square pipe 60 microns powder coated steel frame plywood backing for seat and back, polyurethane foam for seat and back, PU arm rests, upholstered with desired colour of fabric. Set comprises of two chairs fixed together	No.	1		
8	Centre Table with Glass top: Centre Table made with 18mm thick Pre laminated particle board, all exposed edges are covered with PVC tape. Size: 900 x 600 x 450mm Ht.	No	1		
Total amount in Rs.					

Total amount in words: -----

Deputy General Manager

Signature and seal of party

Terms-Conditions

1. Quotation has to be submitted in sealed envelope superscribing “**Quotation for supply of furniture for EMDBP building**” on or before **10.04.2012**. Quotation received after due date shall not be considered for opening and same shall be summarily rejected
2. The quotation submitted should be valid for a period of 30 days from the last date of opening of quotation.
3. Rate quoted by the party shall be inclusive of all materials, labours, taxes, duties, loading-unloading, transportation and nothing extra over and above quoted rate shall be paid.
4. Furniture supplied should have standard warrantee/guarantee of one year from the date of supply. Any defects noticed during the warrantee/guarantee period, same shall be rectified by the party free of cost.
5. Amount shall be paid after delivery and installation of the materials at site. No advance payment whatsoever shall be paid. Necessary TDS as applicable shall be deducted from the amount payable to the party..
6. NSIC reserves the right to accept any or reject all quotations received without assigning any reason thereof.
7. Tables mentioned in the enquiry performa shall be fabricated as per drawings (**ANNEXURE-B**) enclosed by using best materials as per specification.
8. Parties submitting their quotation are advised to visit the site and acquaint themselves about the nature of work and site conditions. Non familiarity with site condition shall not be construed reasons for increasing the rates after accepting offer of the party.
9. Enquiry performa available on website is for information only. Interested parties willing to submit quotation may kindly approach this office alongwith their credentials for issue of enquiry performa.

Deputy General Manager

Signature and seal of the party

Annexure - B'

DGM Table

Qty: 1 Set. Table

Qty: 3 Nos.
(Staff - 2 Nos,
Reception - 1No.)

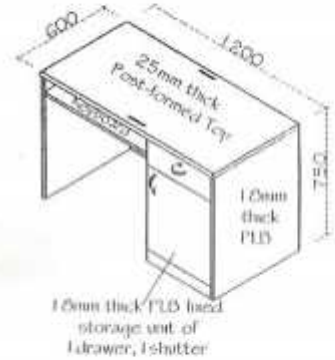
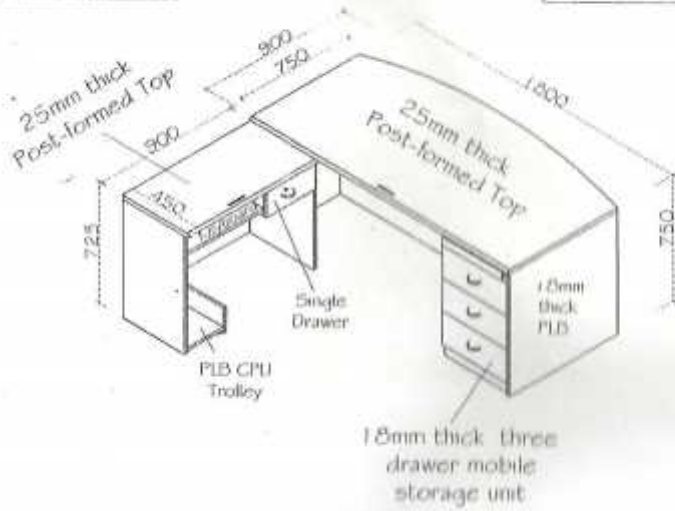

Manager Table

Qty: 2 + 2=4 Sets.

Center Table

